

## Chapter 5 Answers

### Section 5-0

- |                     |                       |                      |                     |                     |                      |
|---------------------|-----------------------|----------------------|---------------------|---------------------|----------------------|
| 1. $x^2$            | 2. $x^{2\beta}$       | 3. $y^{7\beta}$      | 4. $x^3$            | 5. $x^{5\beta}$     | 6. $y^{1\beta}$      |
| 7. $x^4$            | 8. $x^{1\beta}$       | 9. $\frac{1}{y^2}$   | 10. $\frac{1}{x^4}$ | 11. $\frac{1}{x^9}$ | 12. $x^4$            |
| 13. $\frac{1}{x^2}$ | 14. $y$               | 15. $x^{9\beta}$     | 16. $x^3$           | 17. 4               | 18. 9                |
| 19. $\frac{7}{5}$   | 20. $\frac{11}{12}$   | 21. 3                | 22. 5               | 23. $\frac{2}{3}$   | 24. $\frac{-5}{4}$   |
| 25. $\frac{4}{3}$   | 26. 3                 | 27. 3                | 28. 4               | 29. 32              | 30. $\frac{8}{27}$   |
| 31. $\frac{4}{9}$   | 32. $\frac{64}{125}$  | 33. $\frac{16}{9}$   | 34. $\frac{1}{3}$   | 35. $\frac{1}{9}$   | 36. $\frac{1}{2}$    |
| 37. 3               | 38. $\frac{9}{7}$     | 39. $\frac{5}{2}$    | 40. $\frac{4}{3}$   | 41. $\frac{1}{125}$ | 42. $\frac{1}{9}$    |
| 43. $\frac{1}{64}$  | 44. $\frac{1}{4}$     | 45. $\frac{25}{4}$   | 46. $\frac{8}{27}$  | 47. $\frac{9}{4}$   | 48. $\frac{64}{125}$ |
| 49. $\frac{16}{9}$  | 50. $\frac{125}{216}$ | 51. $\frac{27}{125}$ | 52. $\frac{9}{25}$  |                     |                      |

### Section 5 - 1

- |                      |                      |                      |                      |                      |                      |
|----------------------|----------------------|----------------------|----------------------|----------------------|----------------------|
| 1. $x=4$             | 2. $x=3$             | 3. $x=1$             | 4. $x=-1$            | 5. $x=0$             | 6. $x=1$             |
| 7. $x=5$             | 8. $x=0$             | 9. $x=-3$            | 10. $x=4$            | 11. <i>ARN</i>       | 12. $x=6$            |
| 13. $x=2$            | 14. $x=\frac{1}{3}$  | 15. $x=\frac{1}{5}$  | 16. $x=1$            | 17. $x=\frac{-2}{5}$ | 18. $x=\frac{-2}{3}$ |
| 19. $x=\frac{-3}{2}$ | 20. $x=\frac{-1}{3}$ | 21. $x=-1$           | 22. $x=-4$           | 23. $x=0$            | 24. $x=\frac{4}{3}$  |
| 25. $x=\frac{5}{3}$  | 26. $x=3$            | 27. $x=-4$           | 28. $x=-3$           | 29. $x=-3$           | 30. $x=-3$           |
| 31. $x=-2$           | 32. $x=-4$           | 33. $x=\frac{1}{3}$  | 34. $x=\frac{1}{2}$  | 35. $x=\frac{-1}{3}$ | 36. $x=\frac{-4}{3}$ |
| 37. $x=\frac{-2}{3}$ | 38. $x=\frac{-2}{3}$ | 39. $x=\frac{-3}{4}$ | 40. $x=\frac{-3}{2}$ |                      |                      |

## Section 5 – 2: Graphs of the Exponent Function

1)  $y = 2^x$

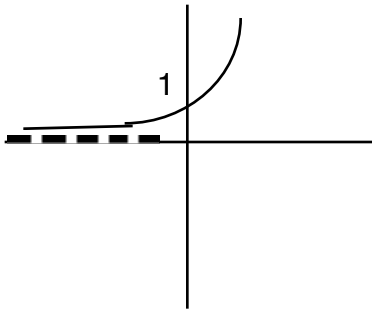

2)  $y = 3^x$

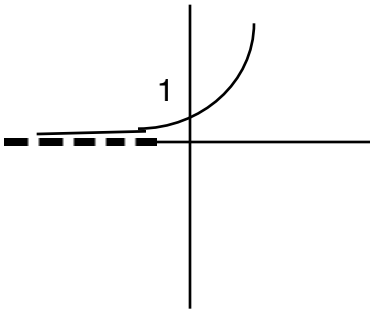

3)  $y = 4^{x+1}$

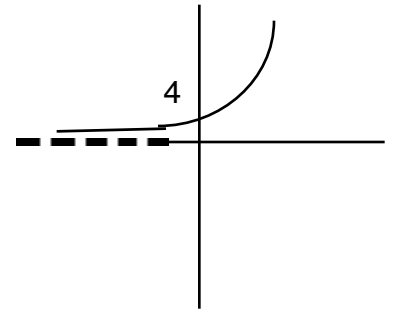

4)  $y = 2^x - 1$

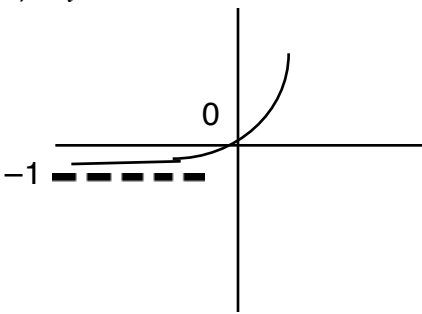

5)  $y = 3^{x-2}$

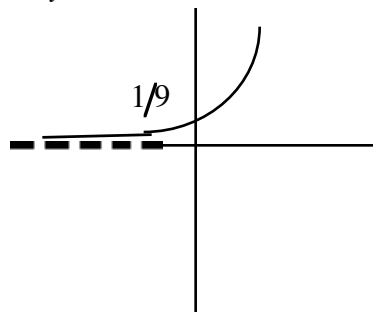

6)  $y = -2^x$

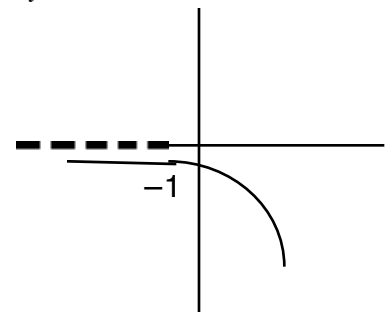

7)  $y = 4^{-x}$

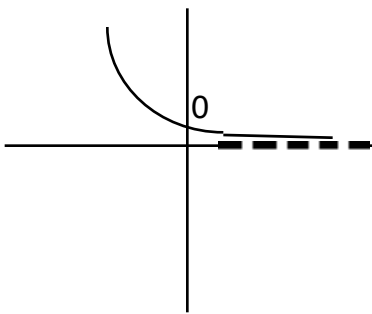

8)  $y = e^x - 3$

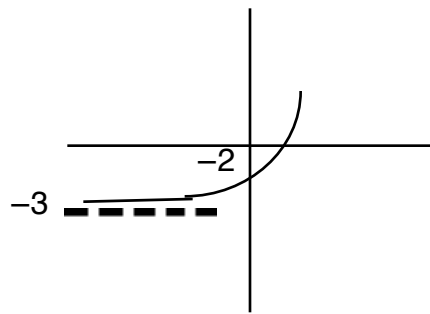

9)  $y = 4^x + 2$

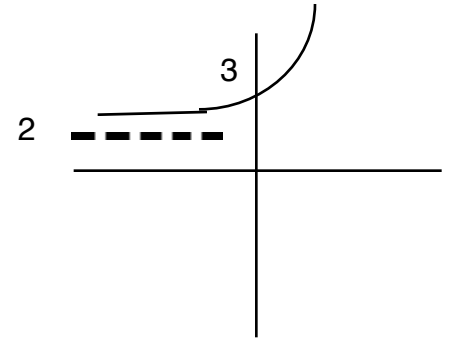

10)  $y = 3^{x+2}$

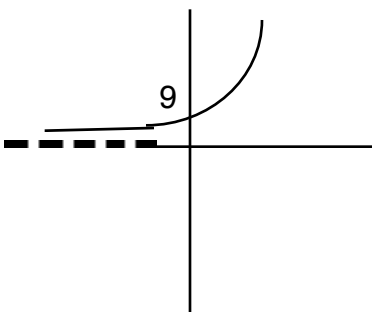

11)  $y = e^x + 1$

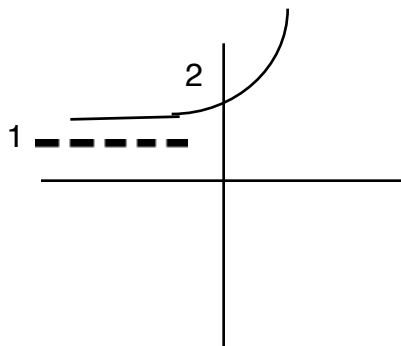

12)  $y = 3^x - 2$

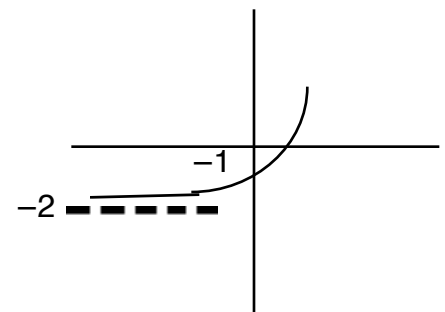

13)  $y = (1/2)^x$

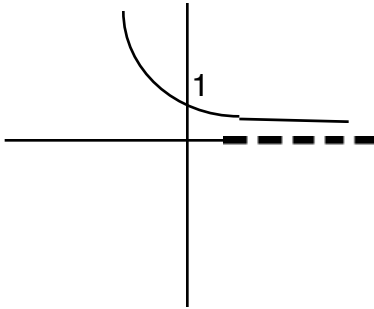

14)  $y = (1/3)^x$

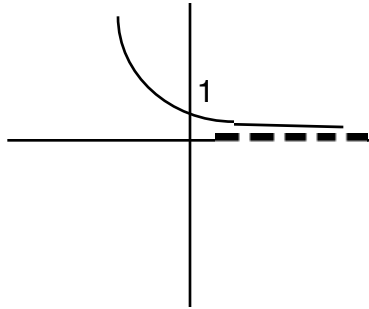

15)  $y = (1/3)^{x-2}$

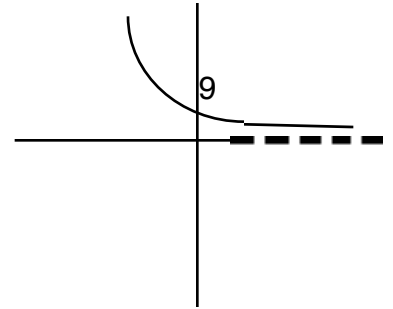

16)  $y = (1/4)^x + 2$

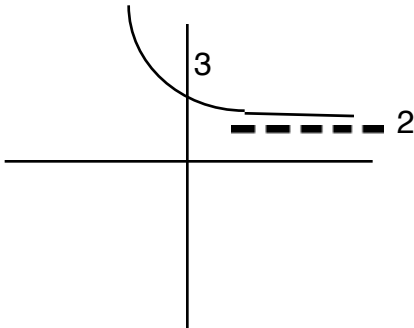

17)  $y = (1/3)^x - 1$

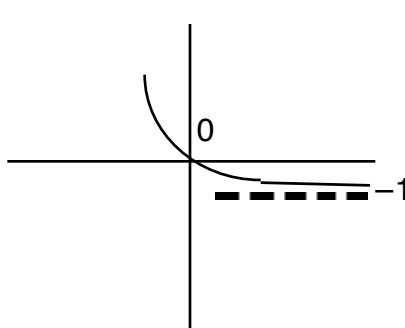

18)  $y = -(1/2)^x$

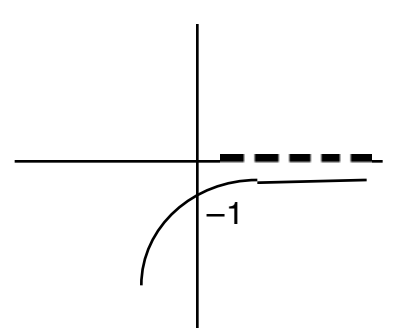

19)  $y = (1/2)^{x+3}$

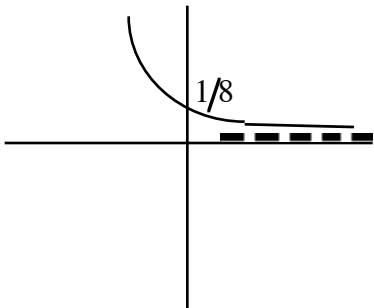

20)  $y = (1/3)^{-x}$

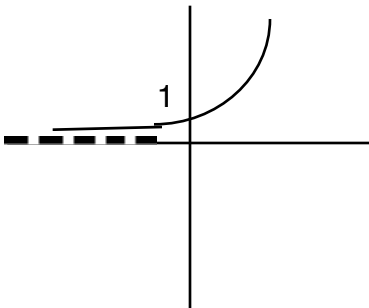

21)  $y = (1/2)^x - 2$

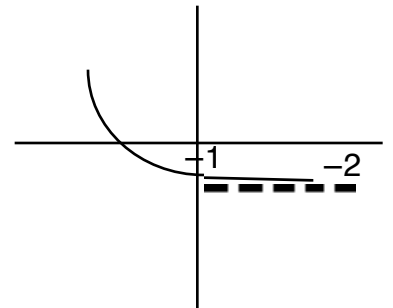

22)  $y = (1/3)^x + 4$

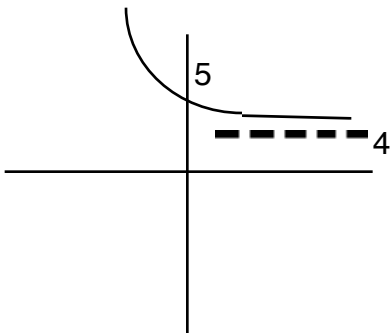

23)  $y = (1/2)^{x-3}$

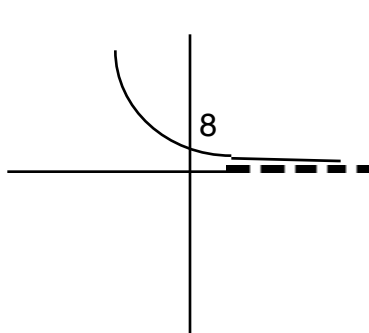

24)  $y = (1/4)^{x+1}$

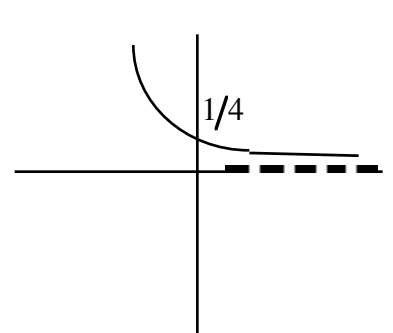

25)  $y = -(3/4)^x$

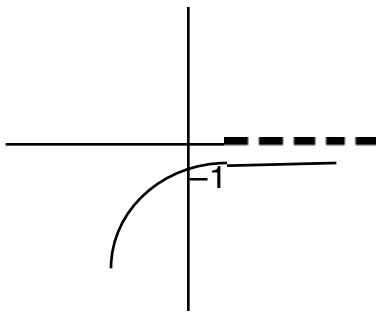

26)  $y = 3^x + 1$

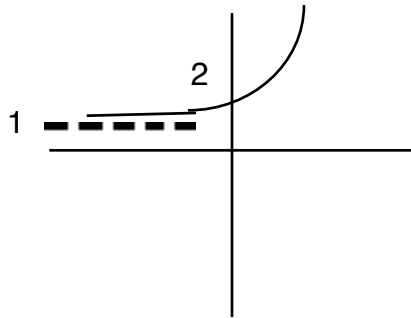

27)  $y = -(1/2)^{-x}$

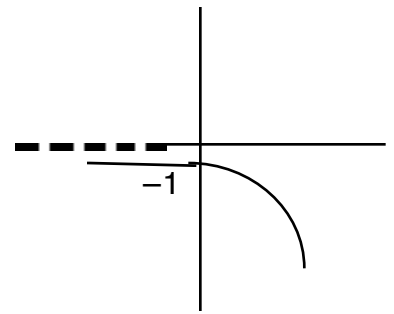

28)  $y = 3^{x+1}$

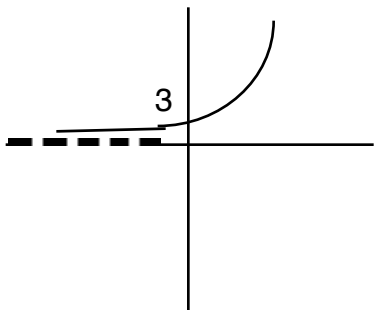

29)  $y = (1/2)^{x-3}$

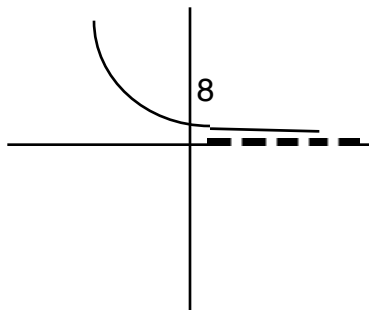

30)  $y = 2^x - 3$

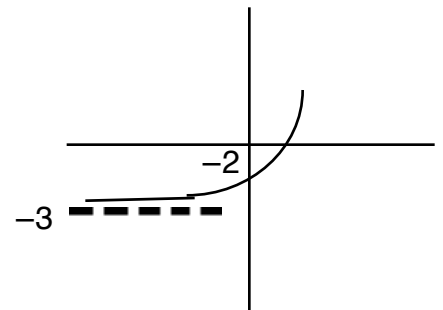

31)  $y = (4/5)^x - 1$

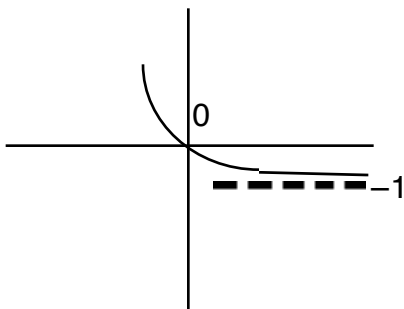

32)  $y = (2/3)^{x+3}$

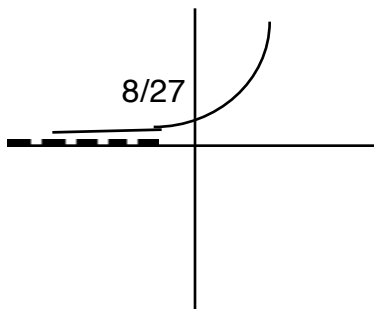

33)  $y = -(5/2)^x$

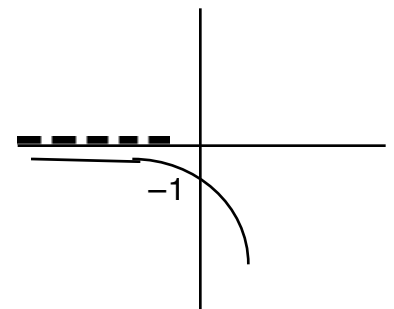

34)  $y = 4^x + 2$

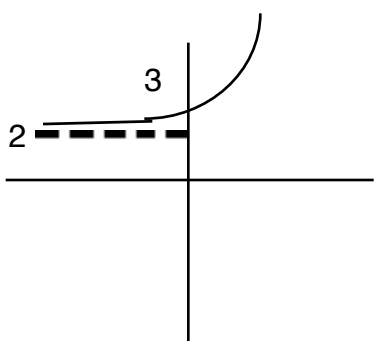

35)  $y = 3^{x-1}$

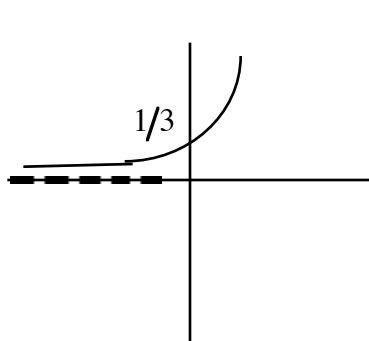

36)  $y = (1/3)^x + 3$

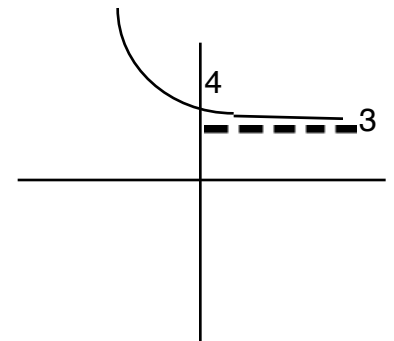

### Section 5 – 3

1.  $\log_3 6 = x$
2.  $\log y = x$
3.  $x = \ln 5$
4.  $\log_7 x = y$
5.  $\ln(x+1) = 2y$
6.  $\log(y-2) = x$
7.  $x = \ln(y+1)$
8.  $\log(x+2) = y$
9.  $\log_{1/2}(y-3) = x$
10.  $\log_3/2(x+2) = y$
11.  $\log_{2/5}(-x) = -y$
12.  $\log_{1/3}(x) = y+2$
13.  $x = 4^y$
14.  $y = x^4$
15.  $5^x = y$
16.  $x^3 = y$
17.  $10^x = 3$
18.  $y = 10^x$
19.  $3 = e^x$
20.  $2 = e^{x-3}$
21.  $x = 2^{y-5}$
22.  $x^5 = y+2$
23.  $x-2 = b^y$
24.  $y = e^{x+4}$
25.  $x1 = e^y$
26.  $x = 2^y$
27.  $5^b = 3y$
28.  $x^8 = 2y-3$
29.  $x = 8$
30.  $x = 27$
31.  $x = .1$
32.  $x = 1$
33.  $x = .01$
34.  $x = 10$
35.  $x = 10000$
36.  $x = 4$
37.  $x = 64$
38.  $x = \frac{1}{32}$
39.  $x = \frac{1}{27}$
40.  $x = 3$
41.  $x = 4$
42.  $x = 5$
43.  $x = \frac{2}{3}$
44.  $x = \frac{3}{2}$
45.  $x = \frac{3}{4}$
46.  $x = \frac{5}{2}$
47.  $x = \frac{1}{2}$
48.  $x = -1$
49.  $x = -4$
50.  $x = -5$
51.  $x = 0$
52.  $x = 10$
53.  $x = 3$
54.  $x = 4$
55.  $1$
56.  $x = 49$
57.  $x = 8$
58.  $x = 125$
59.  $x = \frac{9}{16}$
60.  $x = -2$
61.  $1$
62.  $1$
63.  $4$
64.  $0$
65.  $3$
66.  $0$
67.  $2$
68.  $-2$
69.  $-1$
70.  $1$
71.  $-3$
72.  $1/2$
73.  $-1/2$
74.  $0$
75.  $2$
76.  $0$

## Section 5 – 4: Graphs of the Logarithmic Function

1)  $y = \log_2 x$

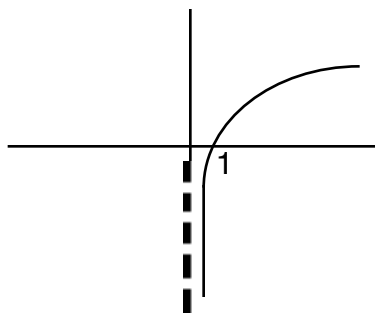

2)  $y = \log_3 x$

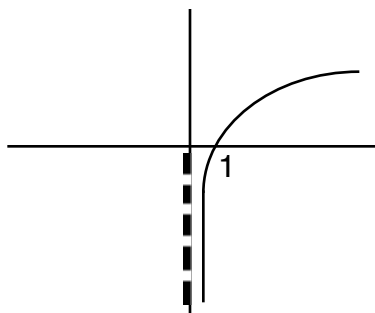

3)  $y = \log_3(x+1)$

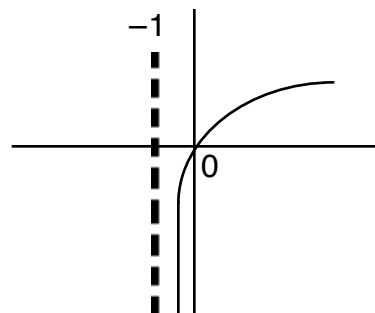

4)  $y = \log_3(x-1)$

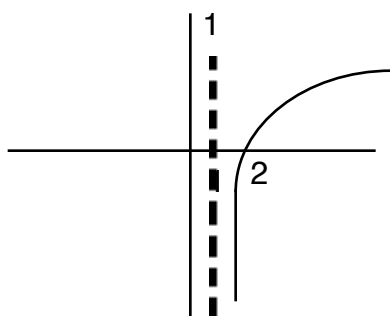

5)  $y = \log_3(x+2)$

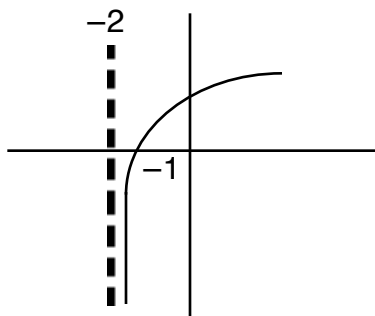

6)  $y = -\log_2 x$

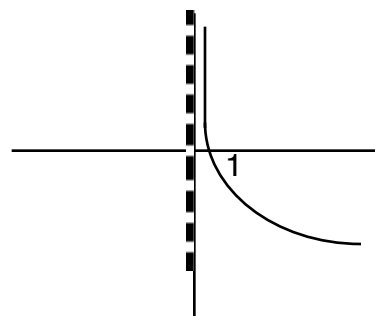

7)  $y = \log_4(-x)$

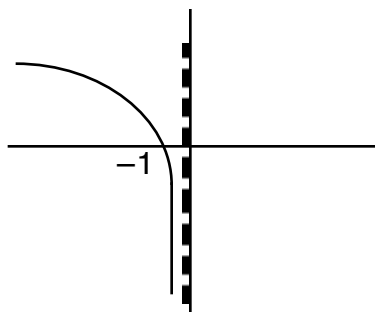

8)  $y = \ln x$

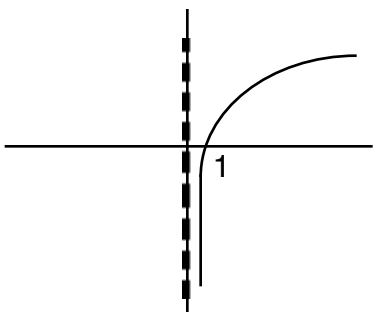

9)  $y = \log(x+3)$

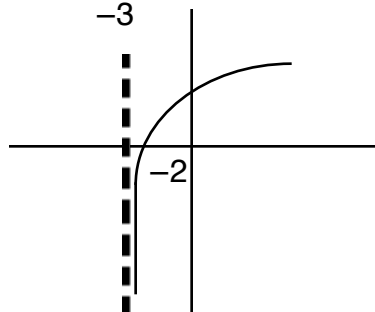

10)  $y = \log_2(x-1)$

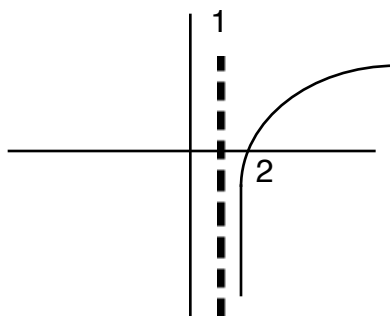

11)  $y = \log_3 x - 1$

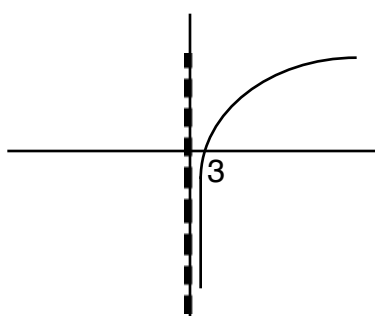

12)  $y = \log_3 x + 2$

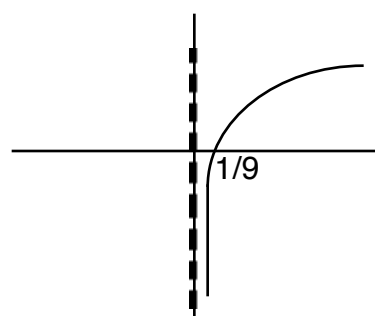

13)  $y = \log_{1/2} x$

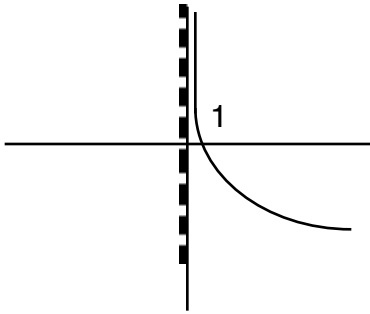

14)  $y = \log_{1/3} x$

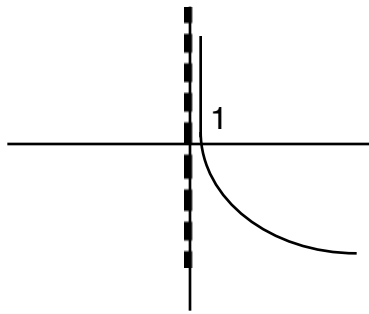

15)  $y = \log_{1/3}(x-2)$

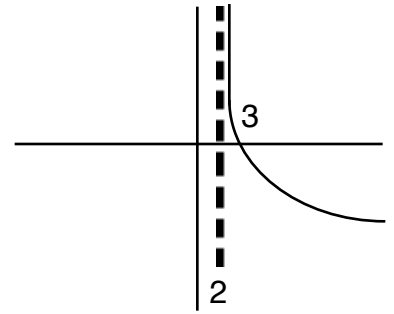

16)  $y = \log_{1/3}(x+1)$

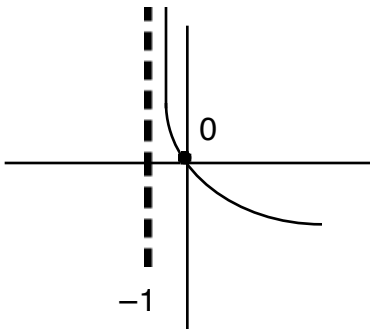

17)  $y = \log_{1/2}(x-3)$

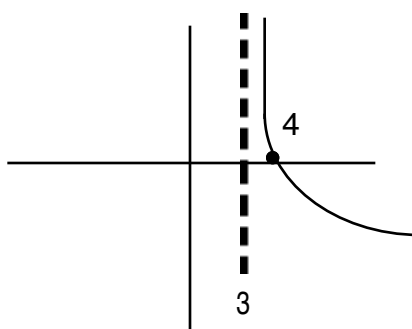

18)  $y = -\log_{1/3} x$

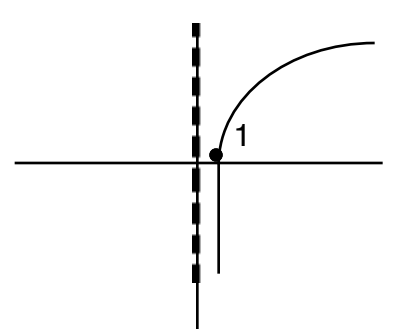

19)  $y = \log_{1/3}(x-1)$

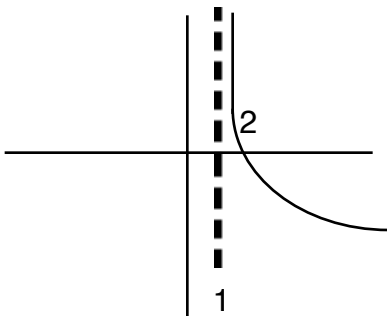

20)  $y = \log_{1/3}(-x)$

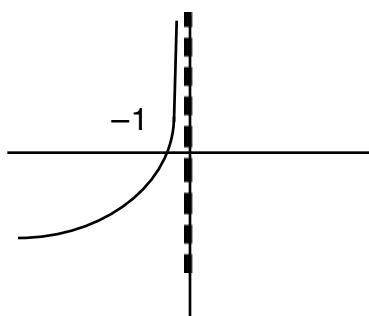

21)  $y = \log_{1/3}(x-2)$

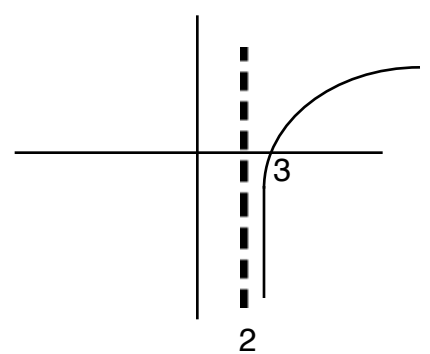

22)  $y = -\log_{1/2}(-x)$

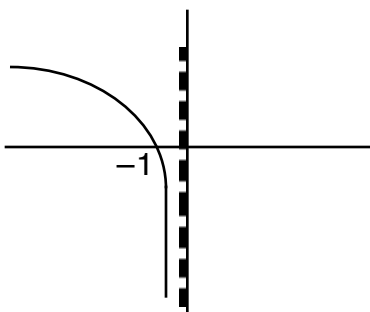

23)  $y = \log_{1/4} x - 1$

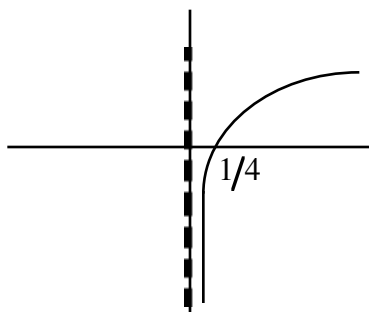

24)  $y = \log_{1/2} x + 2$

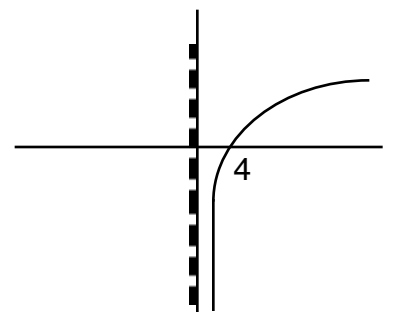

25)  $y = -\log_{1/2}(x)$

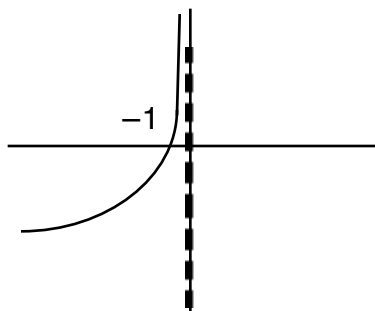

26)  $y = \log_2(x-3)$

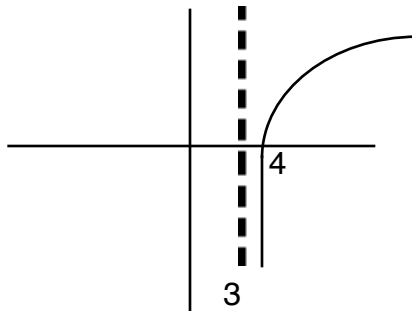

27)  $y = -\log_{1/2}(-x)$

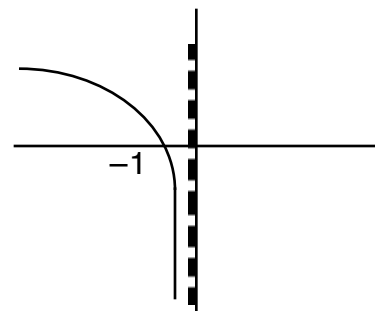

28)  $y = \log_2(x+4)$

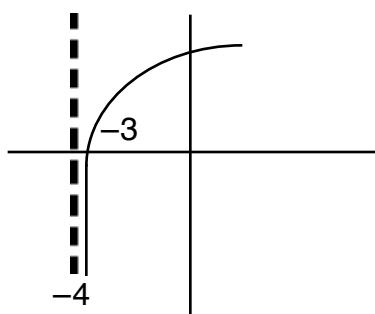

29)  $y = \log_{1/2}(x-3)$

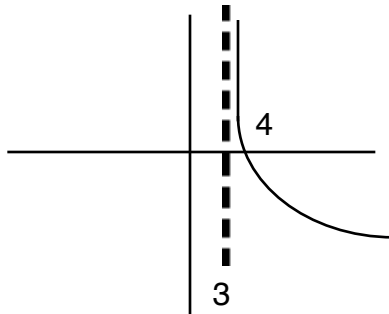

30)  $y = \log_{1/2}(x+1)$

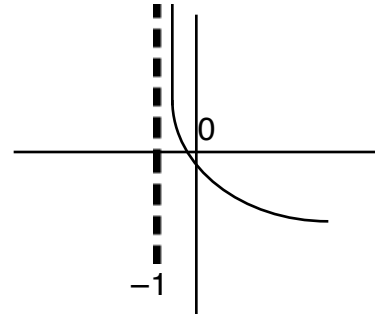

31)  $y = -\log_2(-x)$

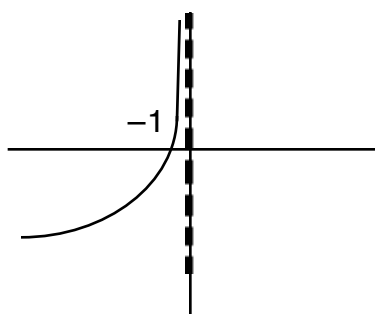

32)  $y = \log_4(x-2)$

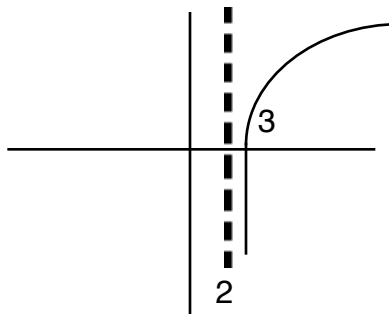

33)  $y = -\log_2 x$

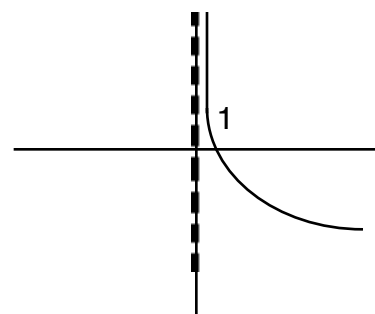

34)  $y = \log_2 x - 2$

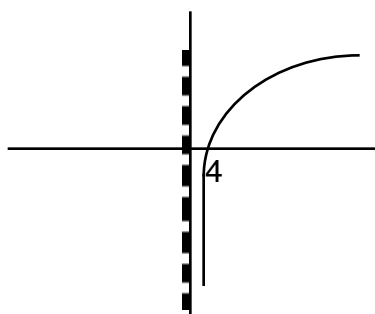

35)  $y = \log_3 x + 2$

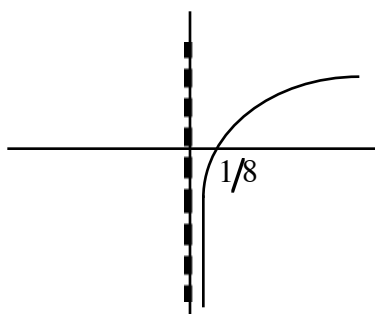

36)  $y = \log_{1/3} x + 1$

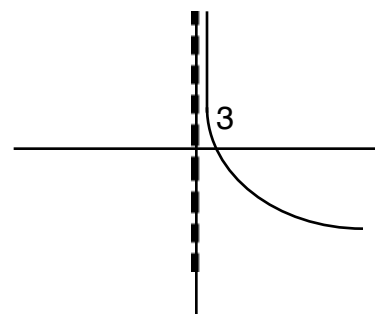

**Section 5 – 5**

1.  $\log_2 5 + \log_2 x$       2.  $\log_3 x + \log_3 y$       3.  $\log_2 8 + \log_2 x + \log_2 y$       4.  $\ln x + 3 \ln y$
5.  $2 \log x + 3 \log y$       6.  $4 + \log_3 x + 2 \log_3 y$       7.  $\frac{1}{3} \log_4 x$       8.  $\log x + \frac{1}{2} \log x$
9.  $4 \log_5 x - 2 \log_5 y$       10.  $2 \log x - 3 \log y$       11.  $\log_2 a + 3 \log_2 x - 4 \log_2 y$
12.  $\frac{1}{2} \log y - \frac{1}{3} \log x$       13.  $\frac{1}{5} \log_4 x - \frac{2}{5} \log_4 y$       14.  $\log 5 - \log(x-1)$
15.  $\log_2(x-1) - \log_2 y$       16.  $\log_6(x^2-9) - \log_6(x+2)$       17.  $2 \log x - \log(x-1)$
18.  $\log_3(x-1) - \log_3(x-4)$
19.  $\log_3 5x^2$       20.  $\log_5 x^2 y^3$       21.  $\log 9x^4 y$       22.  $\log(6x-15)$
23.  $\log(x^2-3x)$       24.  $\log_3(x^3+4x^2)$       25.  $\log(x^2-2x-3)$       26.  $\log_7(x^2-4)$
27.  $\log_4(6x^2+7x-15)$       28.  $\log\left(\frac{16}{x^2}\right)$       29.  $\log\left(\frac{x^2}{y^3}\right)$       30.  $\log_5\left(\frac{x^4}{x-3}\right)$
31.  $\log_5\left(\frac{\sqrt{x}}{\sqrt[3]{x}}\right)$       32.  $\log_3\left(\frac{1}{x+3}\right)$       33.  $\log_3(x^2-2x+4)$       34.  $\log_2\left(\frac{2x-1}{x}\right)$
35.  $\log_2(x^3-3x^2)$

**Section 5 – 6**

1.  $x=6$       2.  $x=-2$       3.  $x=3$  or  $-3$       4.  $x=5$  or  $-2$       5.  $x=5$  or  $-4$       6.  $x=\frac{1}{3}$  or  $\frac{-3}{2}$
7.  $x=-6$       8.  $x=8$       9.  $x=1$       10.  $x=9$       11.  $x=5$       12.  $x=\frac{5}{2}$
3.  $x=-2$       14. No Solution      15.  $x=8$       16.  $x=7$
17. No Solution      18.  $x=\frac{3}{2}$       19.  $x=\frac{2}{3}$       20.  $x=\frac{-3}{2}$       21.  $x=1$
22.  $x=1$       23.  $x=9$       24.  $x=2$

## Section 5 – 7

1. .64      2. -1.17      3. .44      4. 2.76      5. .35      6. 33.12  
7. 1.02      8. .07      9. 4.11      10. 2.54      11. 1.82      12. -5.40  
13. .45      14. -2.22      15. 2.75      16. .77      17. 5011.87      18. .04  
19. 3.7      20. .76      21. 8      22. 1      23. 0      24. 5  
25. 4      26. 8      27. 2.72      28. 1      29.  $x = 281.84$       30.  $x = .01$   
31.  $x = .99$       32.  $x = 10.38$       33.  $x = .05$       34.  $x = .63$       39.  $x = 1.05$       40.  $x = .31$   
41.  $x = -1.06$       42.  $x = -.18$       43.  $x = -.27$       44.  $x = .27$       45.  $x = 1.65$       46.  $x = 8.66$   
47.  $x = .13$       48.  $x = 2.7$       49.  $x = 1.04$       50.  $x = 1.1335$ , pH = 1.03      36. pH = 6.38  
37.  $2.51 \times 10^{-4}$  mol/L penguins      38.  $7.94 \times 10^{-7}$  mol/L      51. 332  
52. 6.13 years      53. 8.03 years      54. 4.55 years  
55. 7.81 grams      56. 233.98 years      57. 646.24 years  
58. \$ 11,040.20      59. \$ 16, 235.58      60. 11.68 years  
61. 36.88 years      62. 7.83 years

## Chapter 5 Review Answers

1.  $x = 5$       2.  $x = -3$       3.  $x = 2$       4.  $x = -2$       5.  $x = 4$       6.  $x = -2$       7.  $x = -4$   
8.  $x = \frac{-1}{2}$       9.  $\log(x - 3) = y$       10.  $\log_3 y = x - 2$       11.  $x = \ln y$       12.  $\log_2(y + 2) = x$   
13.  $x = 4^{y-1}$       14.  $y = 10^x$       15.  $\left(\frac{1}{3}\right)^{x-2} = y$       16.  $y - 3 = e^{x+1}$       17. 2      18.  $\frac{1}{3}$   
19. -2      20. 1      21.  $\frac{3}{5}\log y + \frac{2}{3}\log x$       22.  $\log_2 5 + 2\log_2 x - 3\log_2 y$   
23.  $\ln 3 + \frac{1}{2}\ln x - 2\ln y$       24.  $\ln\left(\frac{\sqrt{x}}{\sqrt[3]{y^2}}\right)$       25.  $\log(8x^3 - 32x^2)$       26.  $\log_5(3x^2 - 4x - 4)$   
27.  $x = 4$       28.  $x = 3$       29.  $x = 25$       30.  $x = -5$       31.  $x = .01$       32.  $x = 15$   
33.  $x = 81$       34.  $x = 2$       35.  $x = 1$       36.  $x = 3$       37. No Solution      38.  $x = 9$   
39.  $x = 8$       41.  $x = \frac{5}{2}$       41.  $x = 1$       42.  $x = 1.40$       43.  $x = .54$       44.  $x = -.66$   
45. pH = 6.25      46.  $2.51 \times 10^{-5}$  mol/L      47. 230      48. 10.2 years

49. 74.32 grams

50. 5473.93 years

51. \$ 25, 720.41

52. 12.97 years

53)  $y = 4^x$

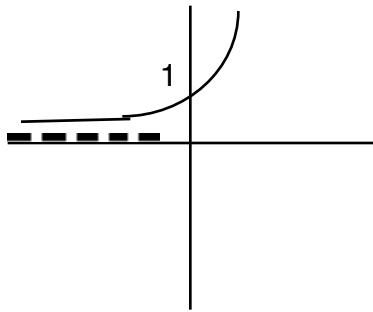

54)  $y = 2^{x+1}$

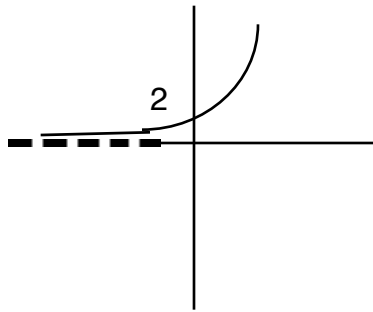

55)  $y = 3^x - 2$

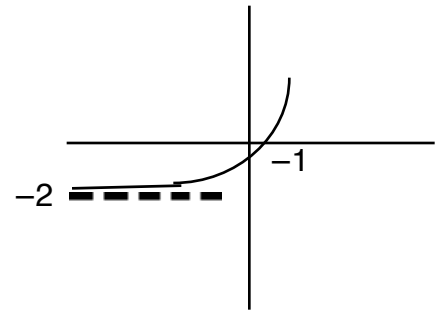

56)  $y = 4^x + 3$

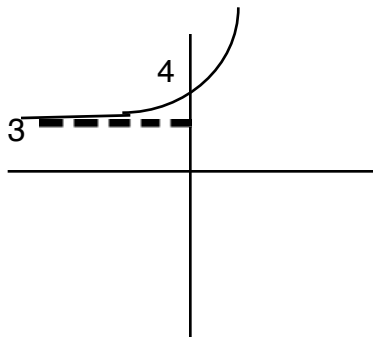

57)  $y = 3^{x-2}$

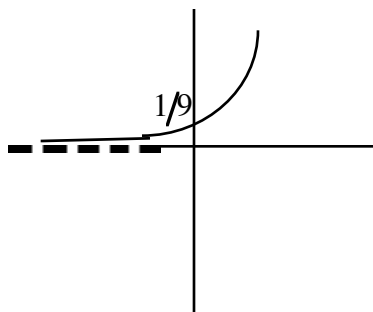

58)  $y = -6^x$

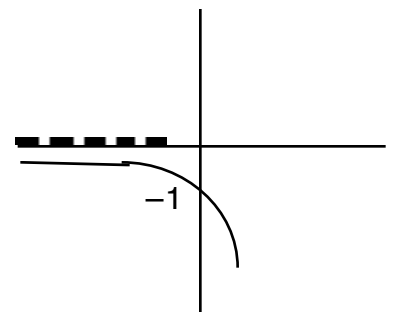

59)  $y = \log_2 x$

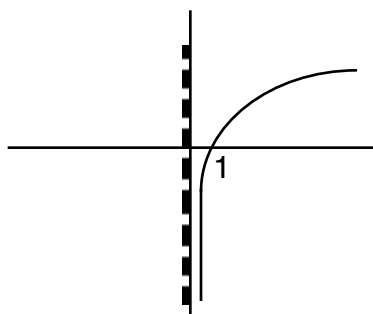

60)  $y = \log_{2/3} x$

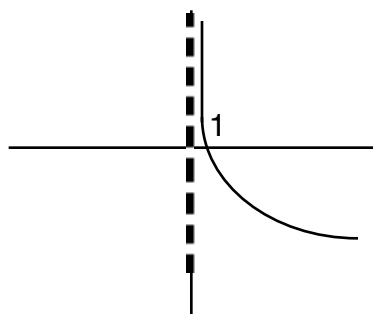

61)  $y = \log_4(x + 2)$

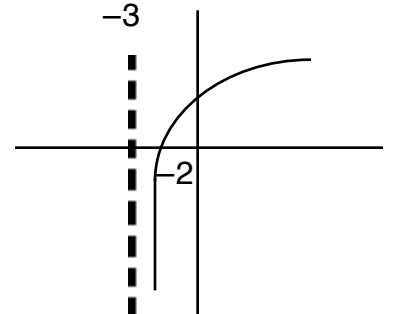

62)  $y = \log_{1/2}(x - 3)$

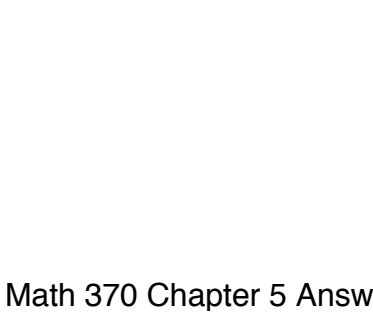

63)  $y = \log_{3/4}(-x)$

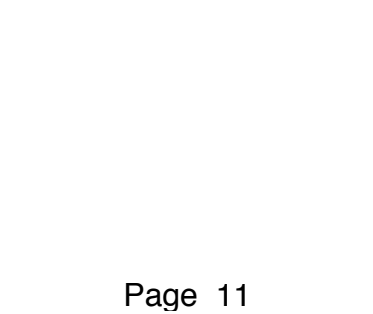

64)  $y = -\log_5 x$



